



Anklesures

Fitting and User Instructions

IMPORTANT NOTES

- Anklesure Foot Control Devices are suitable for attachment to most types of footplate or footboards and may be worn over conventional footwear, i.e. Slippers, Shoes or Trainers, with socks or similar.
- To ensure correct positioning and comfort, it is recommended that these devices be fitted by a suitably qualified person using the enclosed fitting kit.
- The installer may now find it more convenient to remove the footplates / footboard from the wheelchair to complete the drilling and installation of the anchor mountings.
- Anklesures are available in with either Velcro or Buckle fastening.

ANKLESURE KIT contents:-

Left & Right Anklesure Foot Control Devices, 4-Anchor Plates, 8-M5 Screws, Nylock Nuts & Washers, 8-M5 "T" type Nutserts, 8-Self Tapping Screws & 4 Tri-glide Buckles to suit either 25 or 40mm webbing.

 **TOOLS Required:-** Cordless Drill, 3, 5.5 & 6.5mm Drill Bits, 4mm Hex. Key, 8mm Spanner, Pozi-drive size2 Screwdriver and Small Hammer.

FITTING:

- With the user seated in the wheelchair and each foot flat on the footplate or footboard, wrap the Anklesure around the user's ankle, the position of the vertical straps should be noted.

 **NOTE:** As Anklesures are handed, the free end of the adjusting ankle-band straps should be towards the outside of each foot see examples Figs. 1 and 2.



Fig.1 Right side with
Velcro fastening



Fig.2 Right side with
Buckle Fastening

- For "**Velcro**" fastening Anklesures, feed ankle band strap through the buckle and fold strap back on itself.
- Adjust strap to create a snug fit around the ankle, **DO NOT OVER-TIGHTEN** and then secure in the correct position via the Velcro panels.
- For "**Buckle**" fastening Anklesures, connect the ankle band via the Buckle. Adjust strap to create a snug fit around the ankle by pulling the free end whilst holding the plastic tri-glide, **DO NOT OVER- TIGHTEN.**

⚠ NOTE: Before marking the drilling positions on the footplate or footboard for attaching the anchor plates, it will be necessary to consider whether there should be any allowance made for foot movement when the anchor straps are attached. Straps fitted vertically against the user's foot will restrict any sideways movement, whereas straps attached at a slight angle will allow some sideways foot movement. See Figs. 3 & 4 .

- Having established the angle at which the straps are to be mounted, mark the drilling positions for both anchor plates on the footplate / footboard at 45mm centres. These should be towards the rear of the footplate / footboard, taking into account the preferred foot position and any strengthening webs on the underside of the footplate. (see Figs.3 & 4). Repeat the procedure for opposite side.
- The installer may now find it more convenient to remove the footplates / footboard from the wheelchair to complete the drilling and installation of the anchor mountings

- To attach Anklesure anchor plates directly to the wheelchair footplates, drill 5.5mm dia. holes through the footplates at the previously marked positions (avoiding any strengthening webs on the underside).

Insert the M5 Screws supplied, downwards through the anchor plates. Install washers and Nylock nuts on the underside of the footplates and tighten nuts just sufficiently to secure.

FOOTBOARDS

Where a one piece footboard, or individual footboards, are being utilised, it may not be possible to accommodate the M5 Nylock nuts supplied with the anchor plates screws, under the footboard/s.

Where this is the case, two alternatives are available.

- 1) After drilling max. **3mm** dia. pilot holes through the footboard in the previously marked positions, the anchor plates can be attached using the Self Tapping Screws supplied in the fitting kit. **Important Note:** Screws should be tightened by **hand only**, just sufficiently to prevent any movement, using a Pozi-drive screwdriver size 2.

DO NOT USE A POWER DRILL-DRIVER.

- 2) For heavier duty applications, the installer may prefer to attach the Anklesure anchor plates to the footboard/s by using the M5 Screws (supplied) into M5 "T" type Nutserts (supplied), which can be installed into the underside of the footboard.
 - Drill 5.5mm dia. holes through the footboard/s at the previously marked positions.
 - On the underside, counter-bore the holes to 6.5mm dia. to a depth of 6mm. Install the M5 "T" type Nutserts into the footboard and hammer into place to engage the locking tabs.

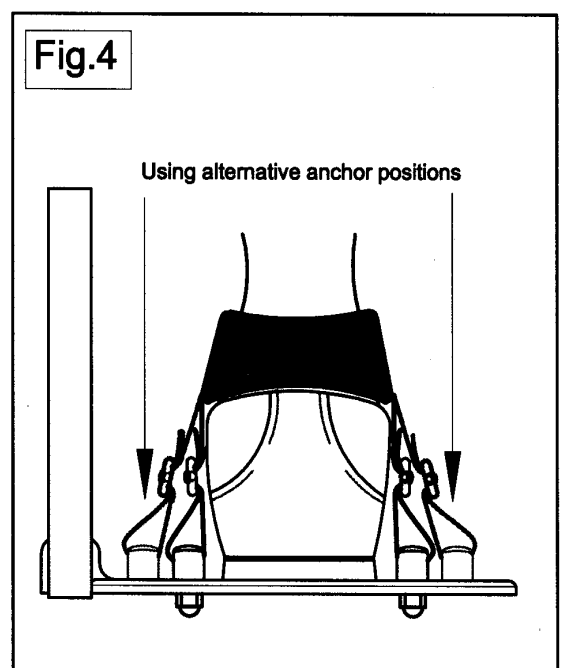
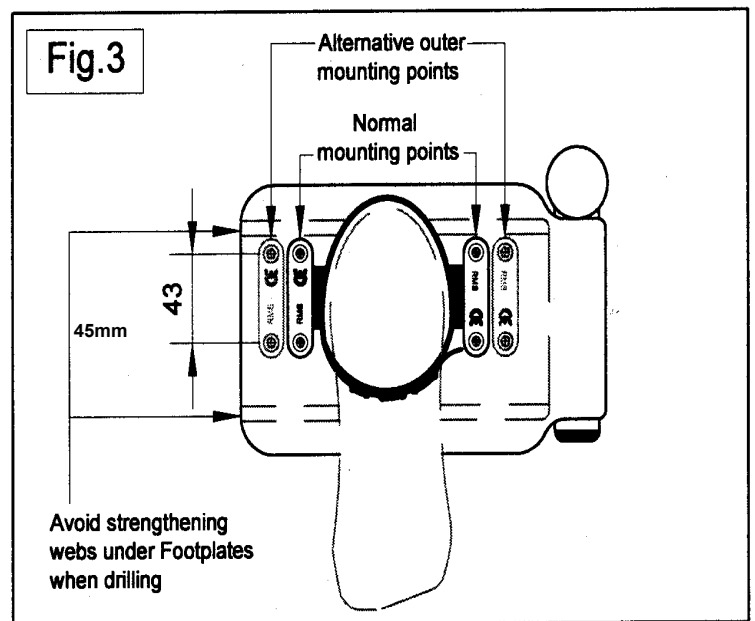

.....continued overleaf

- The anchor plates should then be attached to the footboard/s, by inserting the M5 screws downwards through the anchor plates and screwed into the previously installed Nutserts. Tighten screws just sufficiently to secure.

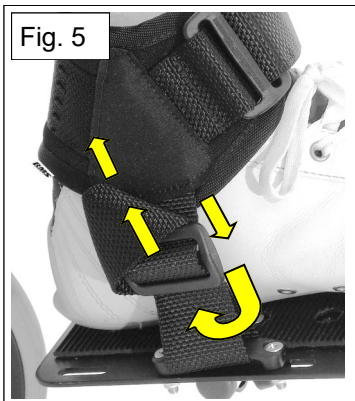

Fig. 5

- Refit footplates and footboard/s to wheelchair and place the user's feet in the required position.
- Wrap each **Anklesure** ankle band around the user's ankle and fasten as previously described overleaf.
- Prior to attaching the vertical straps, it will be necessary to install a plastic tri-glide onto each strap, with the flat surface against the foot as Fig.5.

- Route each strap downwards and then through the anchor plates from the foot side. Taking the free ends back upwards to thread back through the tri-glides as Fig. 5.
- Adjust each vertical strap length to suit the user's requirements and comfort. Any excess free end can be tucked in behind the vertical strap.

⚠ WARNING: For User comfort, care should be taken not to over-tighten the ankle bands or vertical straps.

Guidelines for CARERS

- To avoid unnecessary chafing or rubbing, it is recommended that Anklesures are used over ankle socks or conventional footwear.
- Ensure the User is correctly seated with both feet in contact with the footplates or footboard before adjusting.
- Wrap the Anklesures around each ankle passing the ankle band strap through the plastic loop for ("Velcro" fastened Anklesures). Place one finger inside the Anklesure at the back of the heel and pull adjusting strap through the plastic loop or buckle and secure via the Velcro panels.
- For "**Buckle**" fastened Anklesures, the buckle should be fastened together first, then the ankle band strap can be adjusted by holding the tri-glide with one hand whilst pulling the strap through with the other hand to the required position.

CLEANING:

Anklesures may be machine washed at 40°C and also be cleaned with a sponge using warm soapy water with a little disinfectant added. Ensure the devices are thoroughly dry, before reinstalling.

**MACHINE
WASHABLE
40° C**



Ortho Europe Ltd, Ability House, Nuffield Way, Abingdon, Oxfordshire OX14 1RL.

www.ortho-europe.com

